

# ALPHA-I 15-60

The Alpha Series are available in different interchangeable drive configurations allowing you to tackle any on-site challenge.

Our unique and signature modular design also allows you to quickly and easily convert your Alpha-I series for all your orbital milling applications with our Legacy Milling unit.

## Clamping Capacity

Clamping capacity	mm	inch
Min. Clamping diameter	Ø 379	Ø 15
Max. Clamping diameter	Ø 1358	Ø 54

## Machining Capacity

Machining capacity	mm	inch
Min. machining diameter	Ø 360	Ø 14,25*
Max. machining diameter	Ø 1514	Ø 60*

\* Based on neutral cutting tool

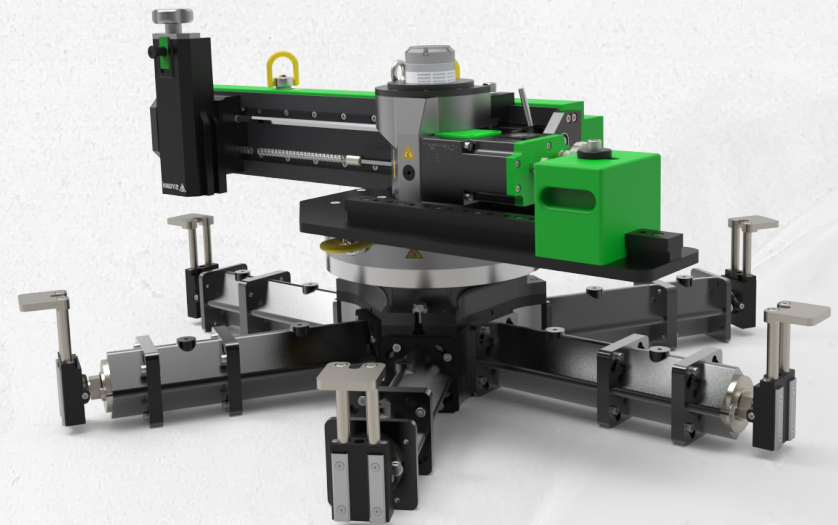
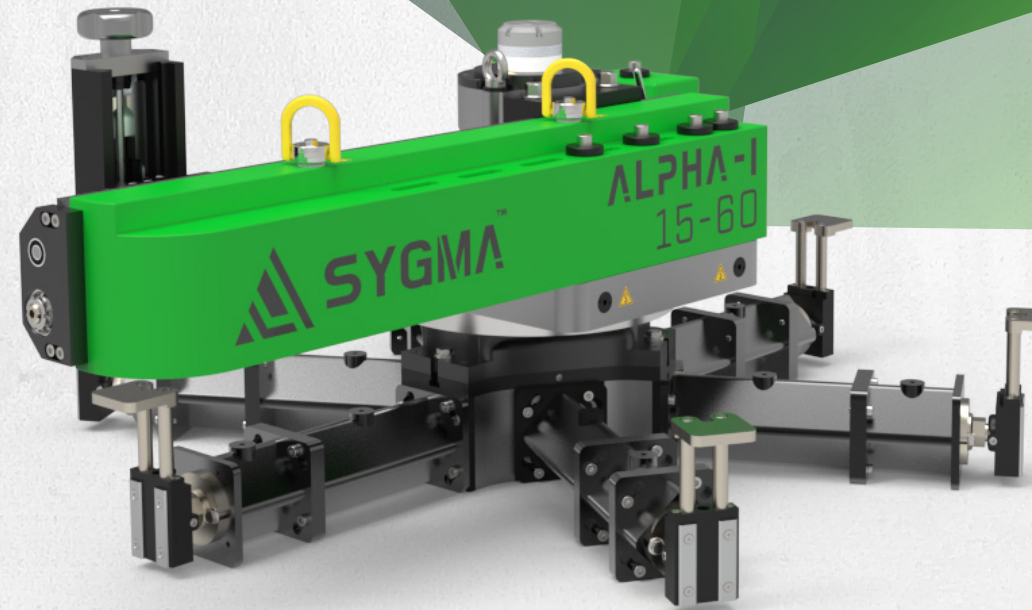

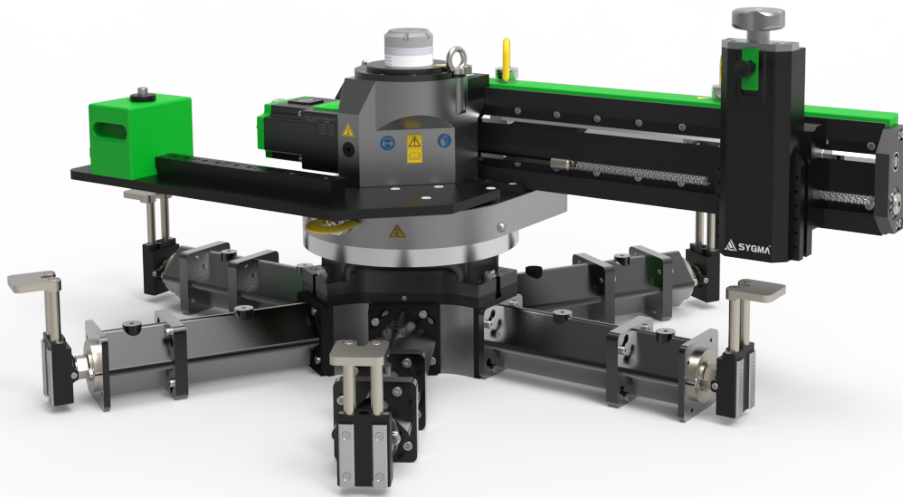

## Key Features

- ⊙ Easy setup & operation (plug & play)
- ⊙ Optimised stability due to high torque output
- ⊙ Zero backlash
- ⊙ Multiple motorization available
- ⊙ Modular Design
- ⊙ Unique integrated safety features
- ⊙ Adjustable clamping feet
- ⊙ Customisable options
- ⊙ In- house engineered heavy duty Ion-4 Gearbox
- ⊙ NO-ROW™ clamping feet

## Accessories

- ⊙ Automatic Toolpost - 360° rotatable with integrated end of stroke limiter (Top and Bottom)
- ⊙ Heat Exchanger Back Facing Kit
- ⊙ Heat Exchanger Mounting Plate Kit
- ⊙ Outside Clamping extension
- ⊙ Orbital Milling Unit (only available with a certain configuration)
- ⊙ Remote control only available with certain options
- ⊙ CNC Servo Drive arrangement
- ⊙ Heavy duty (steel) case

## Dimensional Info & Motorisation

### Case Dimension

1200mm x 900mm x 600mm

### Pneumatic motor supply

2400 W / 3.22 HP

### Overall height Machine

545 mm

### Pneumatic Power supply

2700 l/min

### Overall height Machine

545 mm

## Completed With:

- ⊙ Toolkit
- ⊙ Case
- ⊙ Air Caddy
- ⊙ Hoist Equipment
- ⊙ CE Certificate
- ⊙ Manual

